

DISPLAY | Serve Over Counters

REFRIGERATED DISPLAY CABINETS ▶ SERVE OVER COUNTERS ▶ VENTILATED

WST 150



GAS R290	40 mm	M2 -1°C +7°C	3 +25°C/60RH
LED			

DETAILS

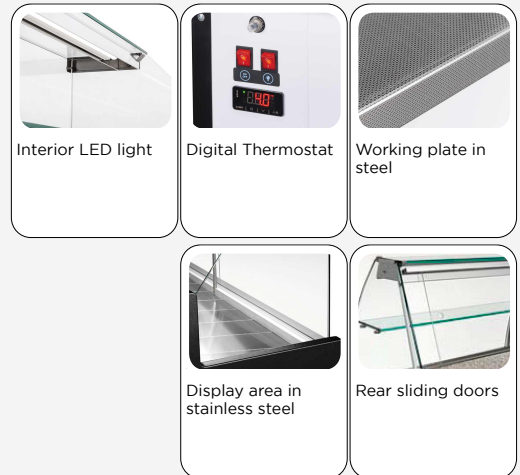

GENERAL FEATURES

- Serve-over refrigerated counter
- Working plate in steel
- Display area in stainless steel
- Ventilated Cooling
- Evaporator with anti-corrosion treatment
- Automatic compressor cycle defrost
- Digital thermostat with "opening door" and "High temperature" alarm
- Cap in vertical tempered glass
- Glass intermediate shelf not refrigerated
- Interior LED light (with independent switch)
- Insulated tank with water base foaming
- N.4 Adjustable feet
- Energy efficiency class: -

TECHNICAL SPECIFICATIONS

Capacity	126 L
Temperature	M2 (-1°C-+7°C)
Consumption	5 kWh/24h
Rated Power	373 W
Noise level	64 dB(A)
Net Weight	162 Kg
Gross Weight	207 Kg
External Dimensions (WxDxH mm)	1500x910x1290
Internal Dimensions (WxDxH mm)	1400x390x220
Packaging dimensions (WxDxH mm)	1600x1050x1130
Loading quantities 20'/40'/40'HQ	14/28/28

PRODUCT DIMENSIONS

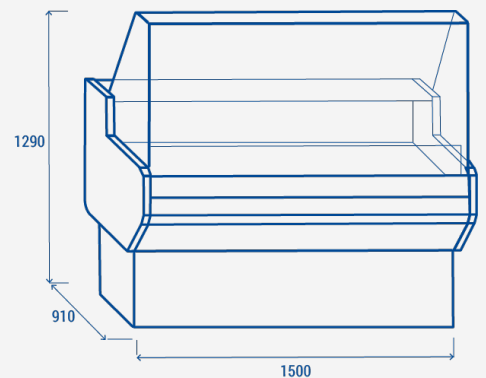

CERTIFICATION

CE RoHS

